

automaticinserts

intelligent fire



© PLANIKA | Ver. 04122017

Fire Line Automatic 2 model E

automatic inserts

FLA2 model E in casing E

Functionality dressed in fire design
Innovative eco-friendly technology

FEATURES:

- BEV* Technology
- No smell / no ash / no smoke
- Optional remote controllable
- Advanced safety sensors
- Automatic shutdown in case of errors
- Child Lock
- Advanced microprocessor
- Diode display
- Control panel
- Intuitive control
- 2 levels of flame height
- Easy installation
- Custom finish option
- No additional installation
- No additional ventilation required
- No chimney required
- Electrical connection required
- For indoor use
- Eco-friendly
- Automatic fuel pump
- Certified
- Fast Start



DIMENSIONS:

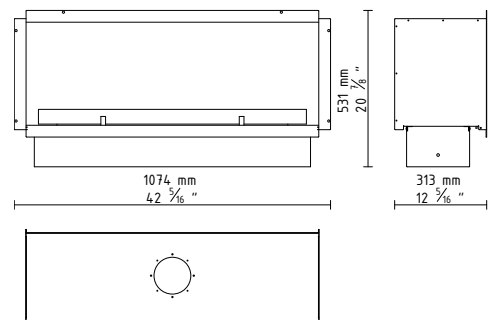

* BEV Technology – A patented process resulting in the clean burning of bio-ethanol fuel vapours.

TECHNICAL DATA:

Capacity: 3,5 L / [US] 0,91 gal / [UK] 0,77 gal
Burning time: 3 - 6 h
Heat output: 3,3 - 6,4 kW / 11396 - 21842 BTU
Net weight: 28 kg / 62 lbs
Air circulation: min. 1/h
Minimum room size:
 please contact our Project Department for details
Power supply: 230 V / 115 V
Finish:
 TOP: black powder coated steel / optional: brushed stainless steel,
 CASING: black powder coated steel, brushed stainless steel, galvanized steel,
 OPTIONAL FRAME: brushed stainless steel,
 GLASS SHIELD: tempered glass

INDOOR INSTALLATION REQUIREMENTS:



INSTALLATION:

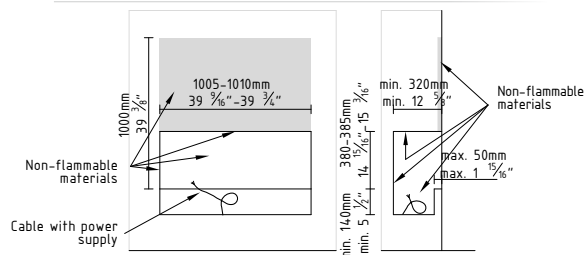

download [PRODUCT INSTRUCTION](#)

